

# DISCTRUSTER CONCEPT

## HYPER EFFICIENT PRESSURE-THRUST DRIVEN AIR-BREATHING AND ROCKET PROPULSION

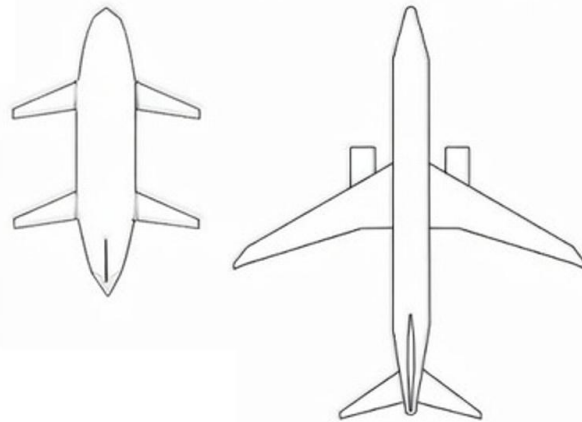

**J. Bradley Pande**  
**iPropulsion, Midway, UT 84049, USA**

This stand-up presentation was given at the American Institute of Aeronautics and Astronautics (AIAA) AVIATION Forum San Diego CA in June 2026. Supporting AIAA paper “DiscThru Concept—Hyper Efficient Pressure-Thrust Driven Air Breathing and Rocket Propulsion.” This stand-up presentation paper may be reproduced in all forms without written consent when accompanied by the following statement: “© 2026 iPropulsion. All rights reserved.”

# Wide Brush Points

1. DiscThruster™ concept creates hyper gains in rocket engine and turbofan performance by maximizing pressure-thrust over momentum-thrust
  - Gains come by eliminating large kinetic energy loss of high velocity exhaust leaving the system
  - Uses very low sonic “choking” fluids that maximize pressure-thrust and minimize momentum-thrust
  - Recapture/recycling fluids

# Let's Start with the Rocket Equation

- Equation is basis of all rocket performance
- First term is momentum-thrust and the second is pressure-thrust

$$T = \dot{m} V_e + A_e (P_e - P_\infty)$$

Where:

$T$  = thrust N (lbf)

$\dot{m}$  = mass flow rate kg/s (lbfm/s)

$V_e$  = velocity of exhaust at the exit plane m/s (ft/s)

$A_e$  = area at nozzle exit plane  $m^2$  ( $ft^2$ )

$P_e$  = pressure of gases upstream of nozzle exit plane Pa (psi)

$P_\infty$  = pressure (usually atm.) downstream of exit plane Pa (psi)

# Momentum-thrust

❑ Hypothetical 500 lbf thrust rocket motor

- 450 lbf Momentum-thrust
- 50 lbf Pressure-thrust

This is where DiscThruster performance gains come from

❑ 2,280 hp of kinetic energy is lost in high velocity exhaust

## Rocket Motor Nozzle

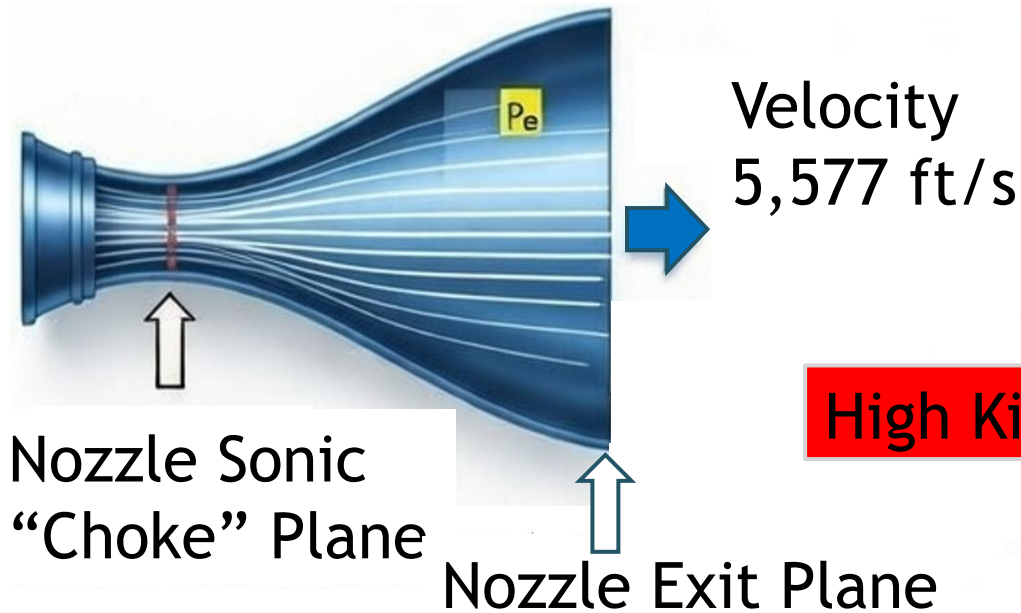

10% Pressure-thrust



90%  
Momentum-thrust

High Kinetic Energy Exhaust Loss

# Falcon 9 Heavy Launch



# Large KE Losses in Rocket Plume

- Hypersonic exhaust has high kinetic energy loss



Space X Falcon 9 Heavy  
Purchased photo: Trevor Mahlmann for Ars Technica

# Pressure-thrust

- ❑ 500 lbf Rocket motor total thrust
  - 238 lbf Momentum-thrust
  - 500 lbf Pressure-thrust
- ❑ 14.2 hp of very low KE losses

DiscThruster uses low choking two-phase fluids to avoid high KE loss

## DiscThruster Nozzle

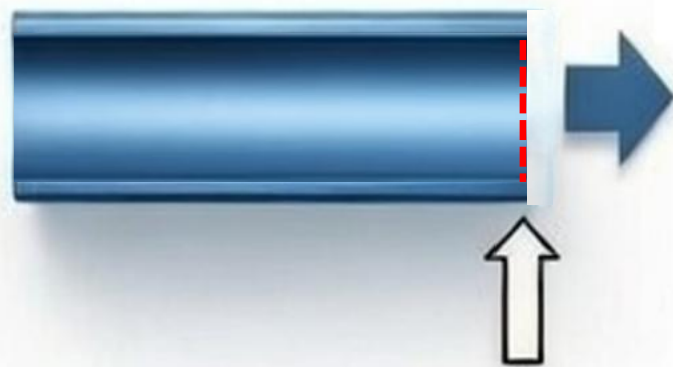

Nozzle  
Exit/Choke  
Plane

Velocity  
17.6 m/s  
(57.7 ft/s)

32% Momentum-thrust



68%  
Pressure  
-thrust

Low Kinetic Energy Exhaust Loss

# DiscThruster

## ❑ DiscThruster baseline

- Uses two-phase fluid: metallic liquid bismuth-tin eutectic and gaseous ethanol, where 97.5% by volume is liquid
- Operates at 325°C (617°F) and 40 bar (580 psi) pressure and sonically chokes at just 17.6 m/s (57.7 ft/s)
- DiscThruster kinetic energy loss is just 0.7% of rocket motor

Thruster	Momentum Thrust [MT] (%)	Pressure Thrust (%)	Exhaust Velocity m/s (ft/s)	Power Loss in Exhaust KW (hp)
Rocket Motor	90	10	1,700 m/s (5,577 ft/s)	1,700 kw (2,285 hp)
DiscThruster	32 → 0 MT set to zero	68	17.6 m/s (57.7 ft/s)	10.6 kW (14.2 hp)

# Static Thrust Stand 1.0



- ❑ Thruster nozzle mounted on inverted pendulum thrust stand
  - Uses converging-only rocket nozzle, measuring thrust for two-phase water/air mixtures
  - Momentum-thrust and pressure-thrust measured

# DiscThruster 2.0 - No Fluid Capture

Gas engine

Thrust stand

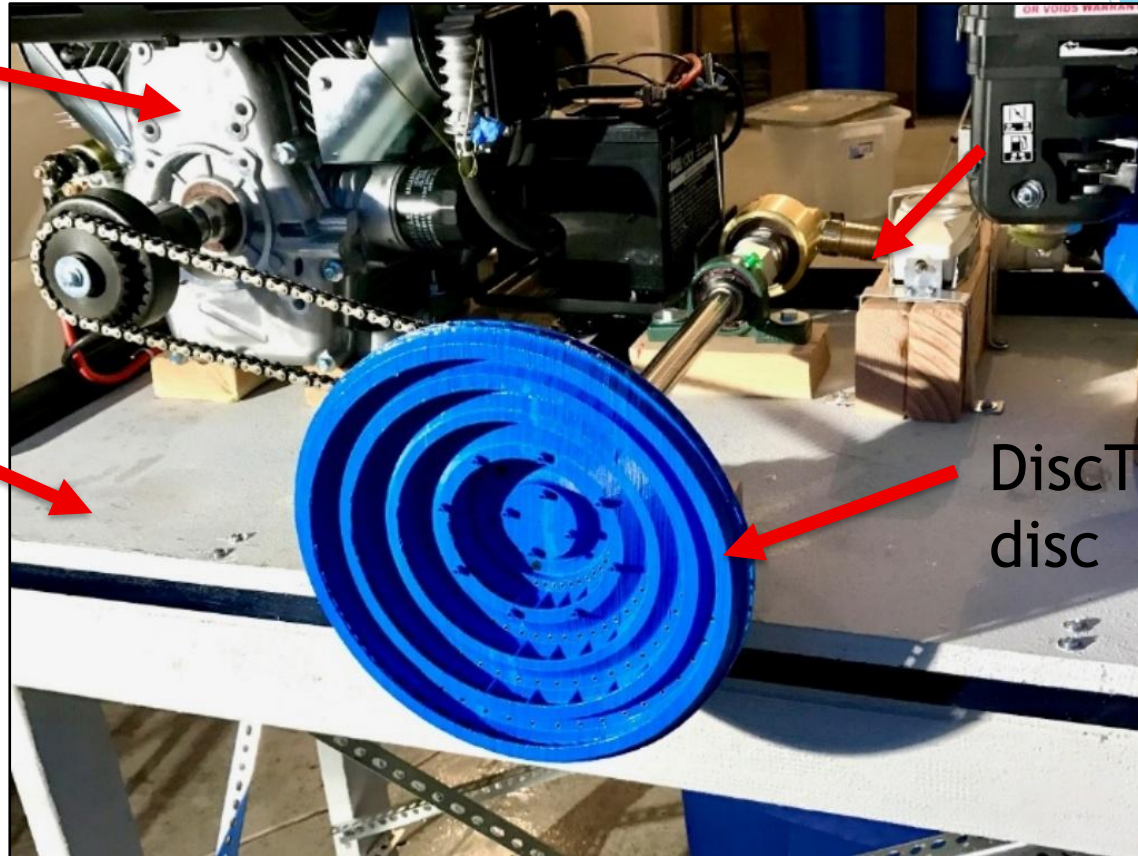

DiscThruster disc

- ❑ Spinning disc has no fluid capture capability
- ❑ Fluid passes between three rows of 48 nozzles each and exits at right angles to rotation axis, while producing no thrust

# DiscThruster 2.0 - No Fluid Capture

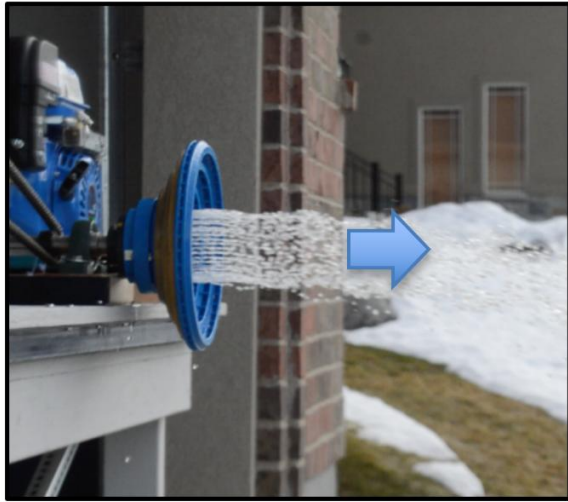

Video 1

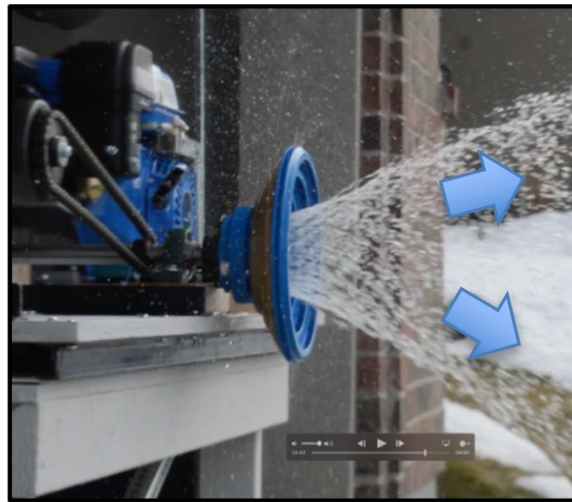

Video 2

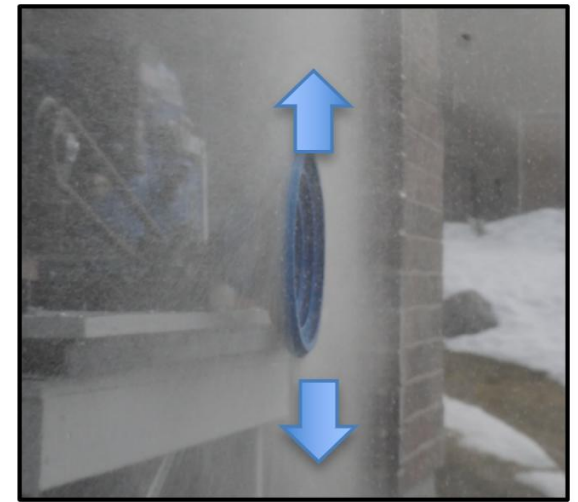

Video 3

- Video 1 - Water flowing - no disc rotation
- Video 2 - Disc begins to spin up and fluid starts to “bend”
- Video 3 - Disc spinning at full speed (5,300 rpm) causing fluid to flow at 90-degree angle and leave the system

# DiscThruster 3.0 - Fluid Capture/Recycle

16 kW (22 hp)  
gas engine  
(spins disc)

Gas engine  
water pump

Volute (fluid  
capture/recycle)

Impulse turbine  
(removes KE  
from flow)

Thrust stand  
(slides on linear  
bearings)

DiscThruster  
Disc

Water reservoir  
(receives water from  
volute and  
recycles it back to  
DiscThruster disc)

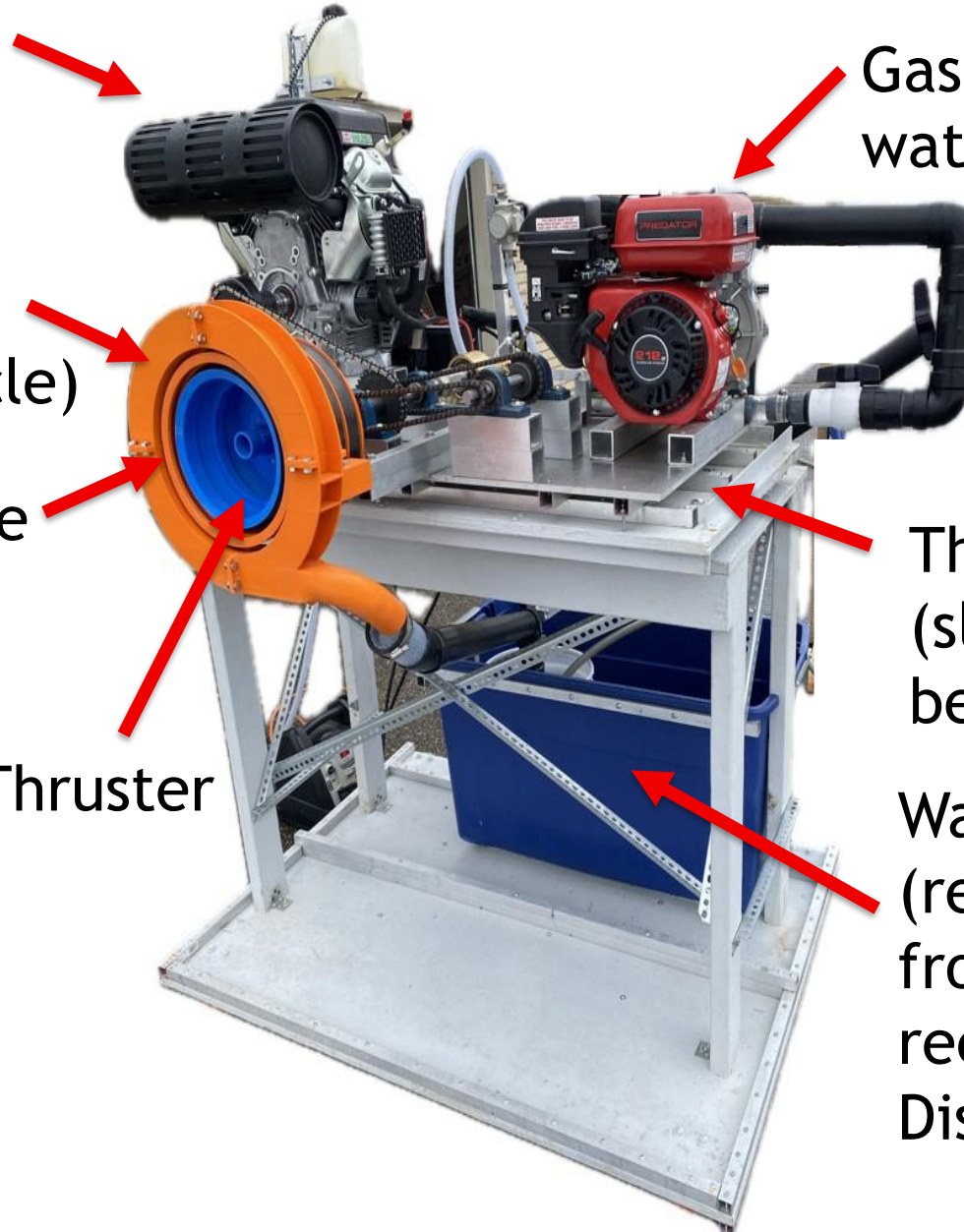

# DiscThruster 3.0

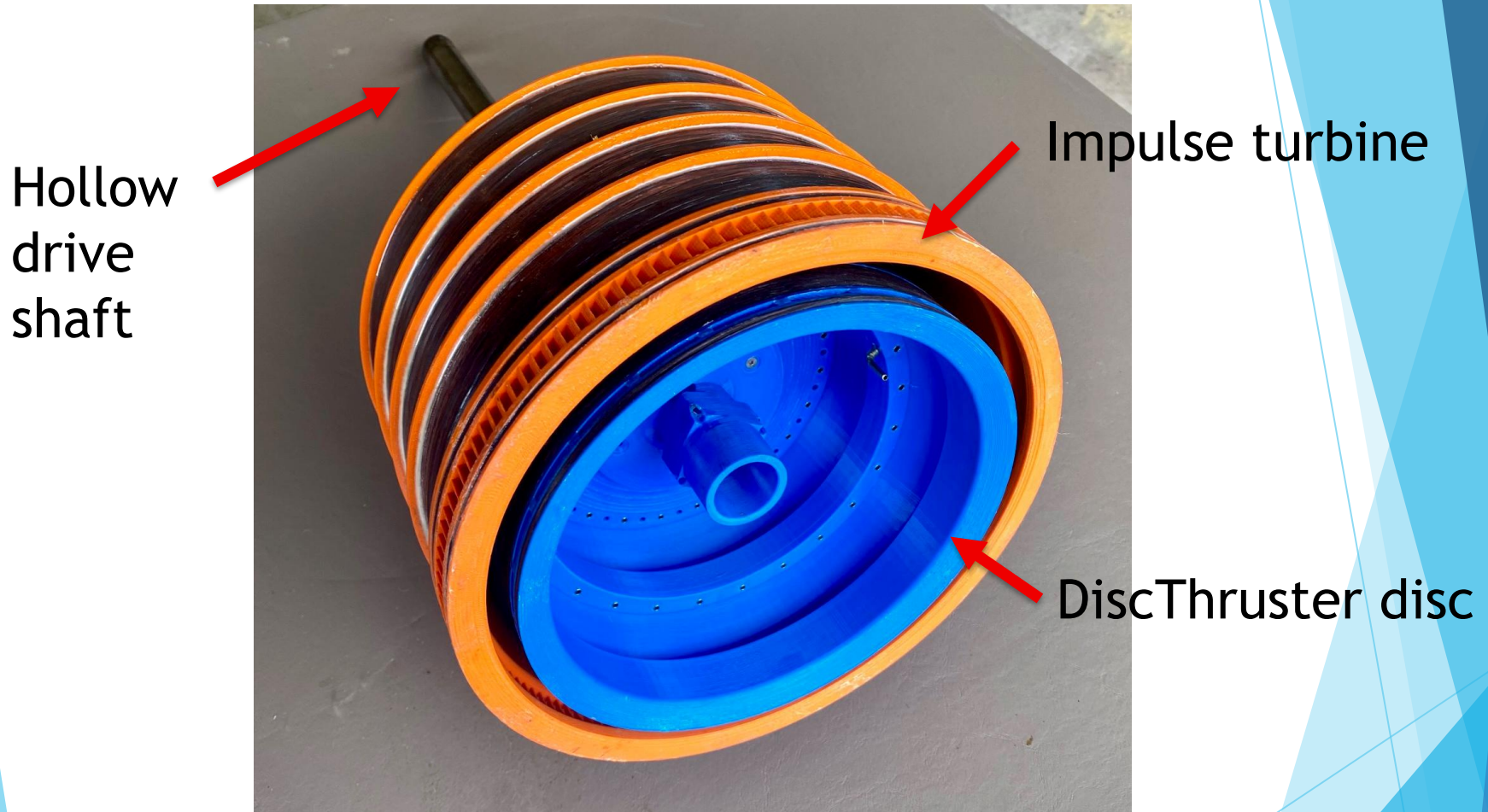

- ❑ DiscThruster 3.0 has added an impulse turbine and volute for fluid capture

# DiscThruster 3.0

Volute  
Cavity  
to  
collect  
fluid

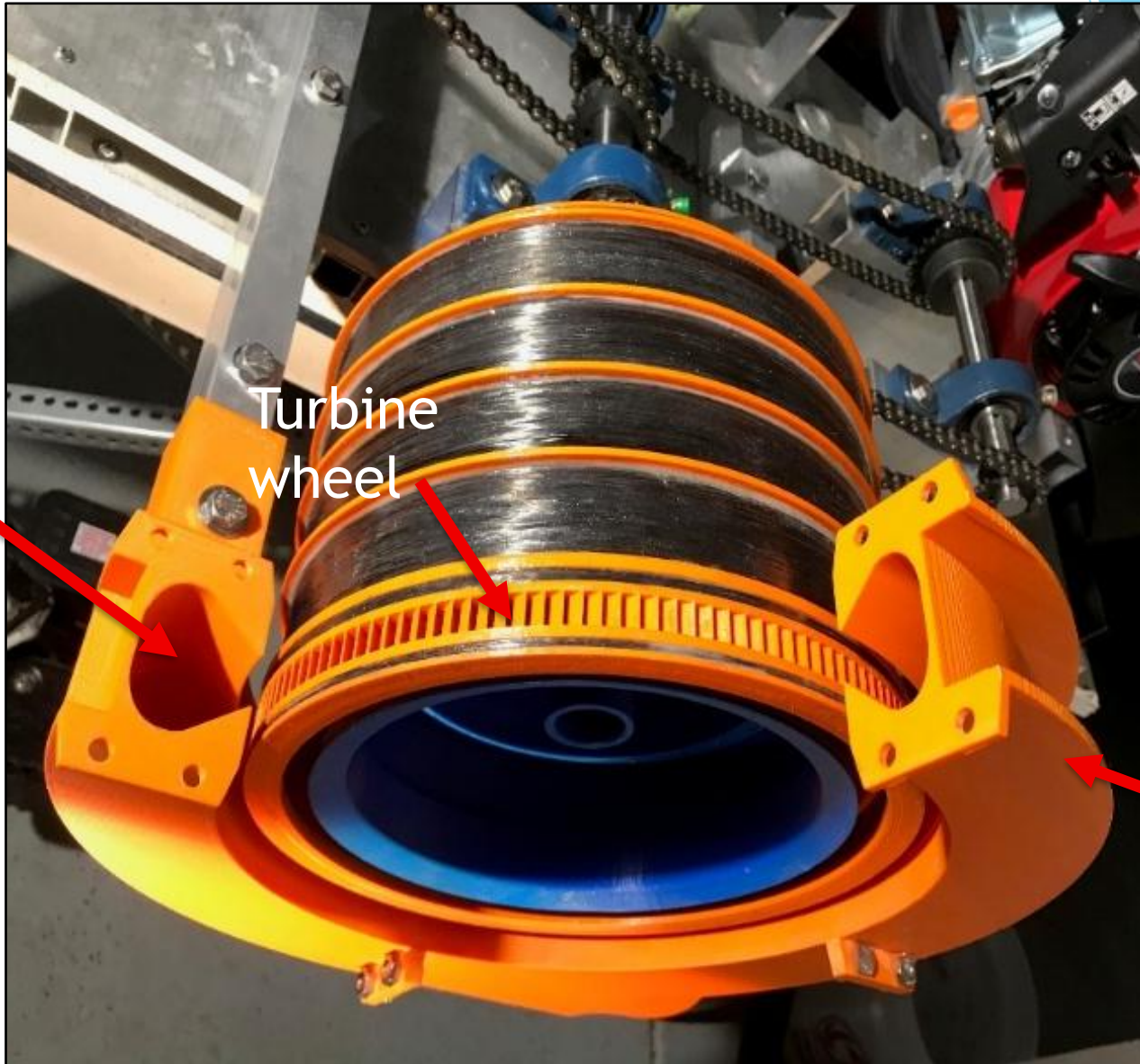

Turbine  
wheel

Volute

# DiscThruster 3.0 - Drive Gear

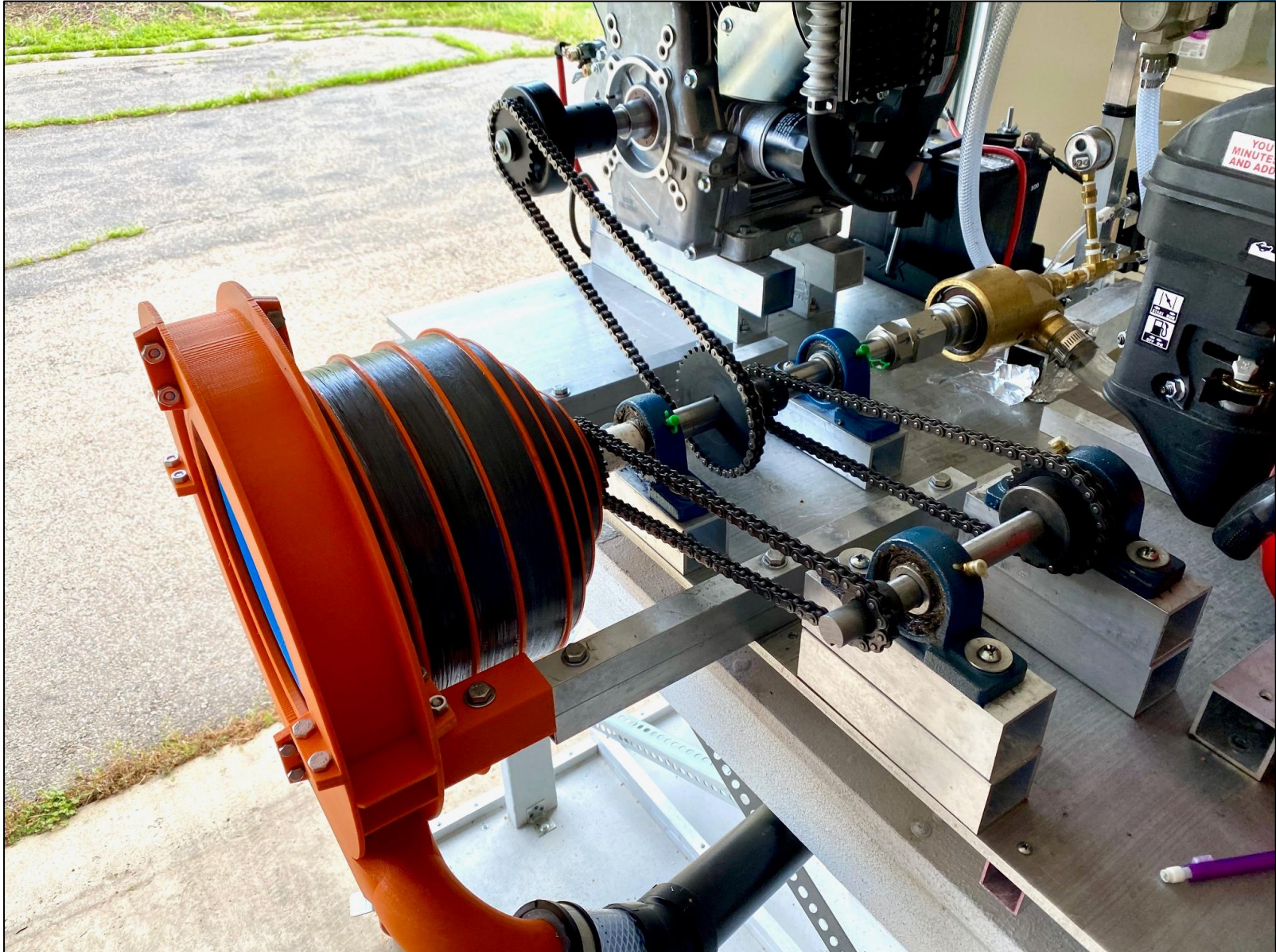

# DiscThruster on Wing



- ❑ DiscThruster and turbofan on wing comparison
  - Boeing 737 shown
  - Center of thrust matches turbofan to simplify certification



# DiscThruster vs. Modern Turbofan

- ❑ DiscThruster matches turbofan thrust
  - Uses smaller turboshaft engine to drive system
  - Predicts 81% reduction in fuel burn over turbofan engine
  - Has large built-in performance margin for unknowns

## Cruise Thrust Specific Fuel Consumption (TSFC) g/(kN·s) (lbm/(lbf·hr))

Thrust kN (lbf)	Modern Turbofan	Disc- Thruster	Reduction in Fuel Burn (%)	Knockdown to Meet 50% Lower Fuel Burn
129 (29,000)	14.59 (0.515)	2.78 (0.098)	81	2.6

# DiscThruster Space Launch Engine

- ❑ Launches into space using electric motor and rechargeable battery pair (replaces turboshaft/ambient air)
  - Operates as one-way or round-trip single stage to orbit (SSTO) by recharging batteries in space

Engine Specific Impulse (Isp) N/(kg/s) (lbf/(lbm/s))			
Rocket Engine	DiscThruster	Gain in Isp Factor	Knock-down to Meet 2X or Doubling of Isp
380	2,403	6.3	3.2

# SetllarJet - The Art of the Possible

- ❑ Intercontinental range commercial aircraft
  - Coasts above atmosphere using vertical thrusters

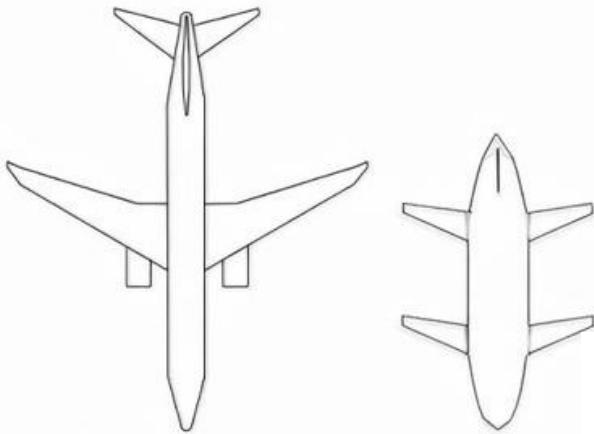

Boeing 737  
and StellarJet  
side by side  
comparison

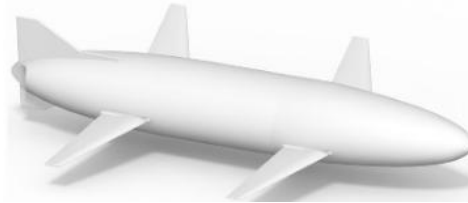

StellarJet's folding wings

# Takeaways

## Results

Extensive experimental campaigns over several years have successfully validated a pathway to a functional DiscThruster

- Delivering TSFC 50% lower than modern turbofans
- Two-fold improvement in Isp over modern rocket engines

## Challenges

Rigorous independent verification and a dedicated team required to advance to next milestone:

- 1.1 kN (250 lbf) thrust demonstrator requiring a committed three-year sponsorship

Thank You

J. Bradley Pande iPropulsion

Contact: [brad.pande@ipropulsion.com](mailto:brad.pande@ipropulsion.com) Cell: 801.828.0897

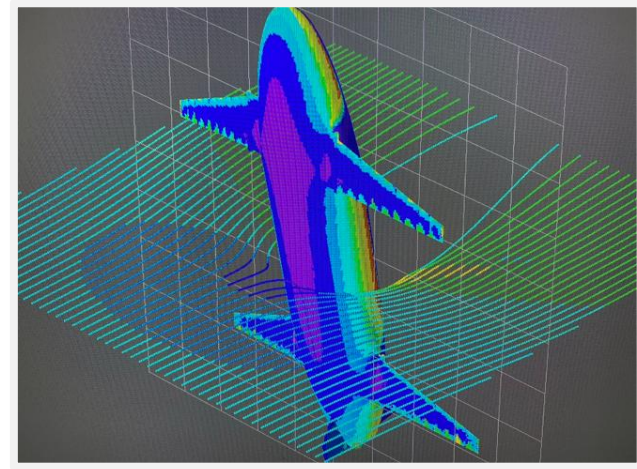

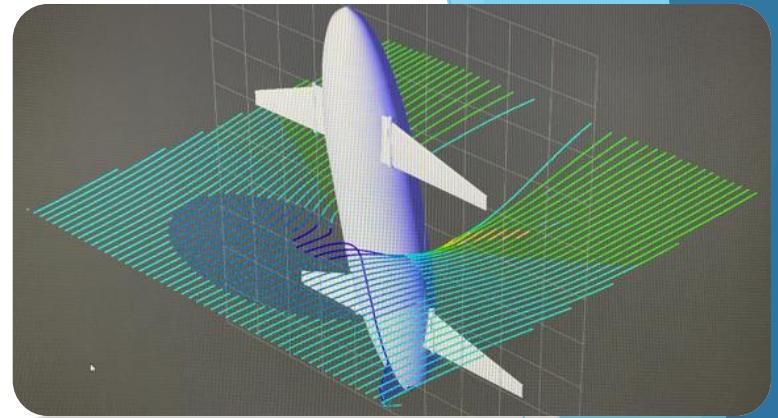

# Thankyou

Website: [iPropulsion.com](http://iPropulsion.com)

Contact:

[brad.pande@ipropulsion.com](mailto:brad.pande@ipropulsion.com)

Cell: 801.828.0897

# BACKUP

# Rocket Equation Example

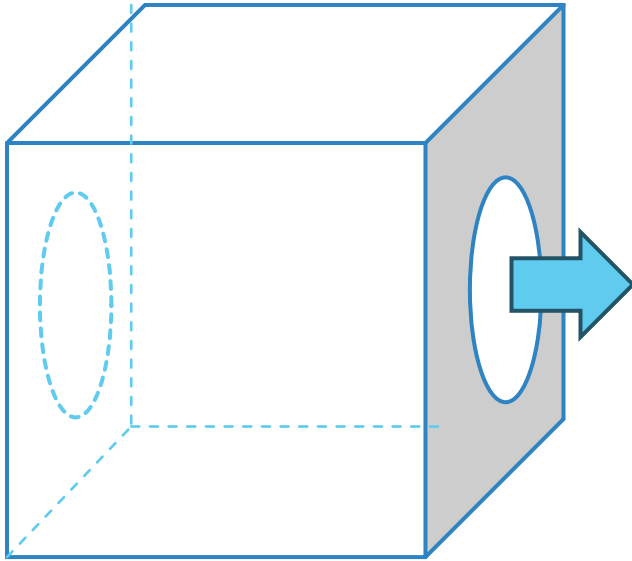

$$F_{\text{top}} = F_{\text{bottom}} = 0.0 \text{ Thrust}$$

$$F_{\text{side}} = F_{\text{rside}} = 0.0 \text{ Thrust}$$

Pressure Thrust

$$100 \text{ psig} \times 0.25 \text{ in}^2 = 25 \text{ lbf}$$

Momentum Thrust

$$1 \text{ lbm/s} \times 100 \text{ ft/s} = 3.1 \text{ lbf}$$

$$\text{Total Thrust} = 25 + 3.1 = 28.1 \text{ lbf}$$

- ❑ Pressure thrust is a force imbalance between front wall (w/hole with delta pressure across hole) and back wall (w/o hole).
- ❑ Momentum thrust is acceleration of mass out of hole and reaction on back wall.

- 1-inch cube pressurized to 100 psig
- 0.25 in<sup>2</sup> choking hole (A)
- Exit fluid chokes at 100 ft/s
- Mass flow rate = 1 lbm/s

# Reciprocating/Pulsing Concept

- With cap removed cylinder moves downward at same speed as fluid's choking velocity
  - Fluid exits sonic choke point with zero velocity, no momentum-thrust

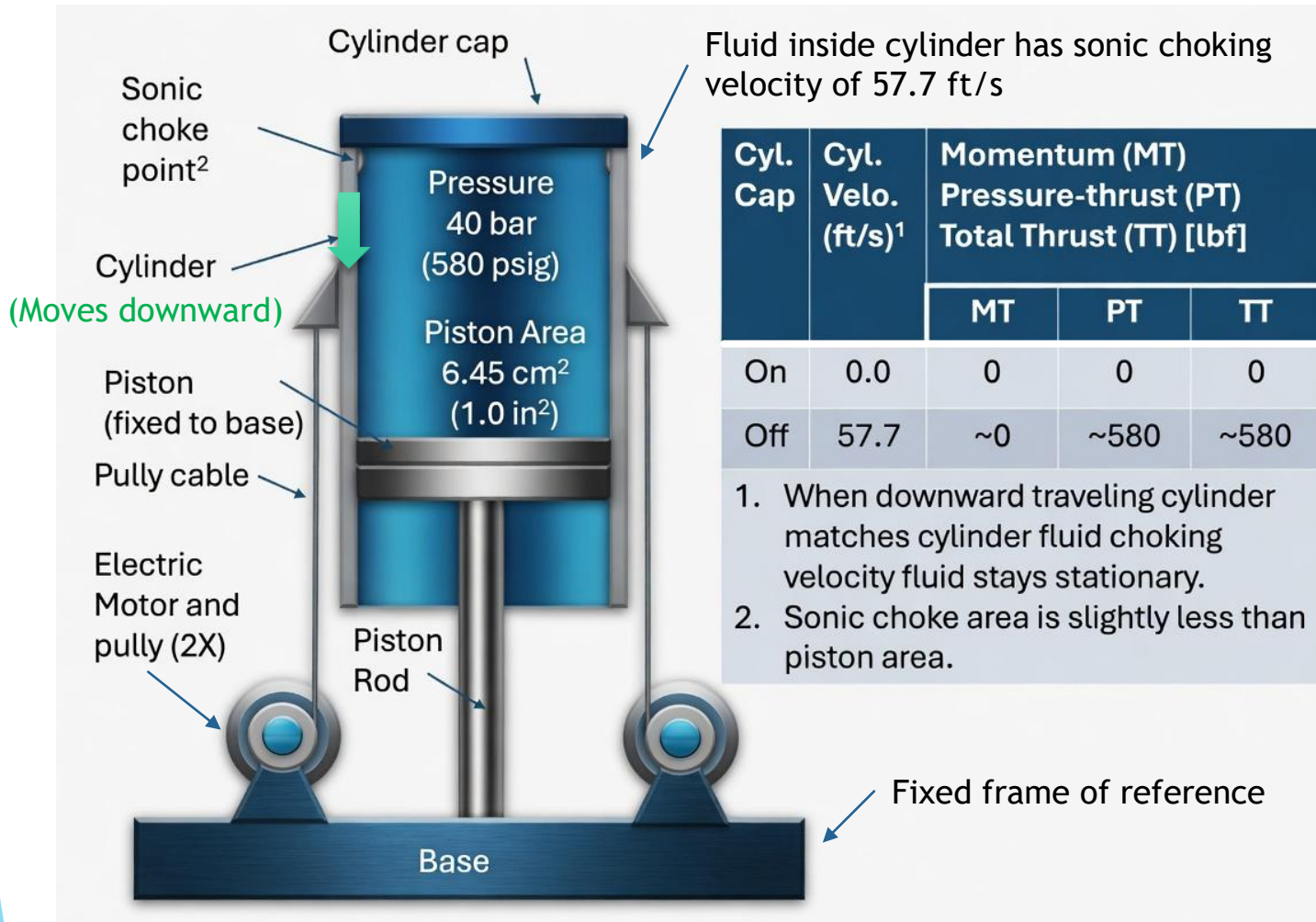

# DiscThruster 4.0 and 5.0

## DiscThruster 4.0

- ❑ Stationary disc with embedded nozzles. Rotating sweeper blades collect fluid exiting nozzles
  - Capture/Recycle design

## DiscThruster 5.0

- ❑ Nozzles Reciprocate back-and-forth along nozzle centerline while sonically choking fluid
  - When moving nozzle velocity equals fluid choking velocity, fluid exits with zero velocity and zero momentum-thrust, simplifying rotating sweeper blade fluid collection
  - Capture/Recycle Design

# Pressure Blow-down Testing

□ Thrust vs. time recorded during blow-down testing

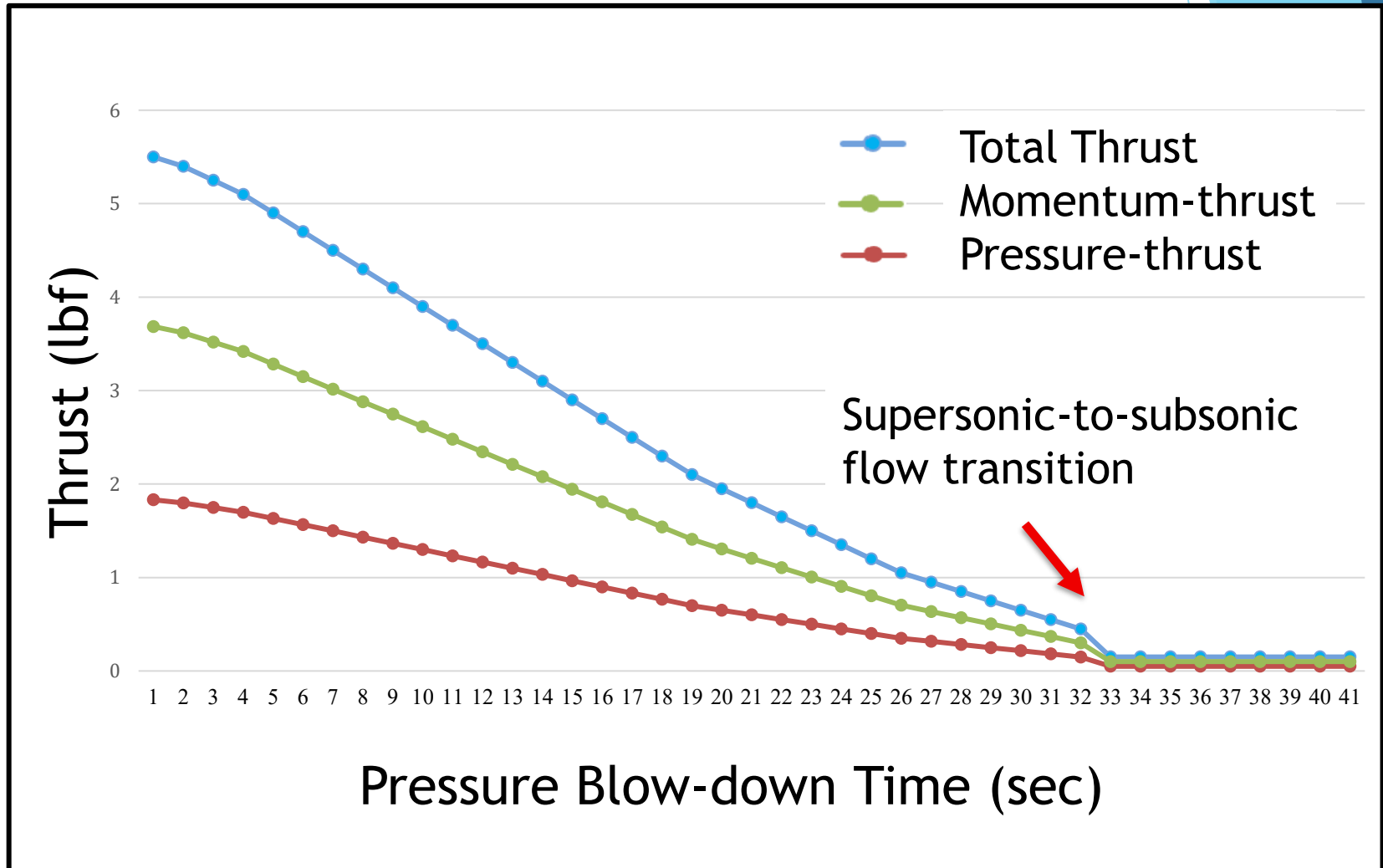

# DiscThruster 3.0 - Disc and Impulse Turbine

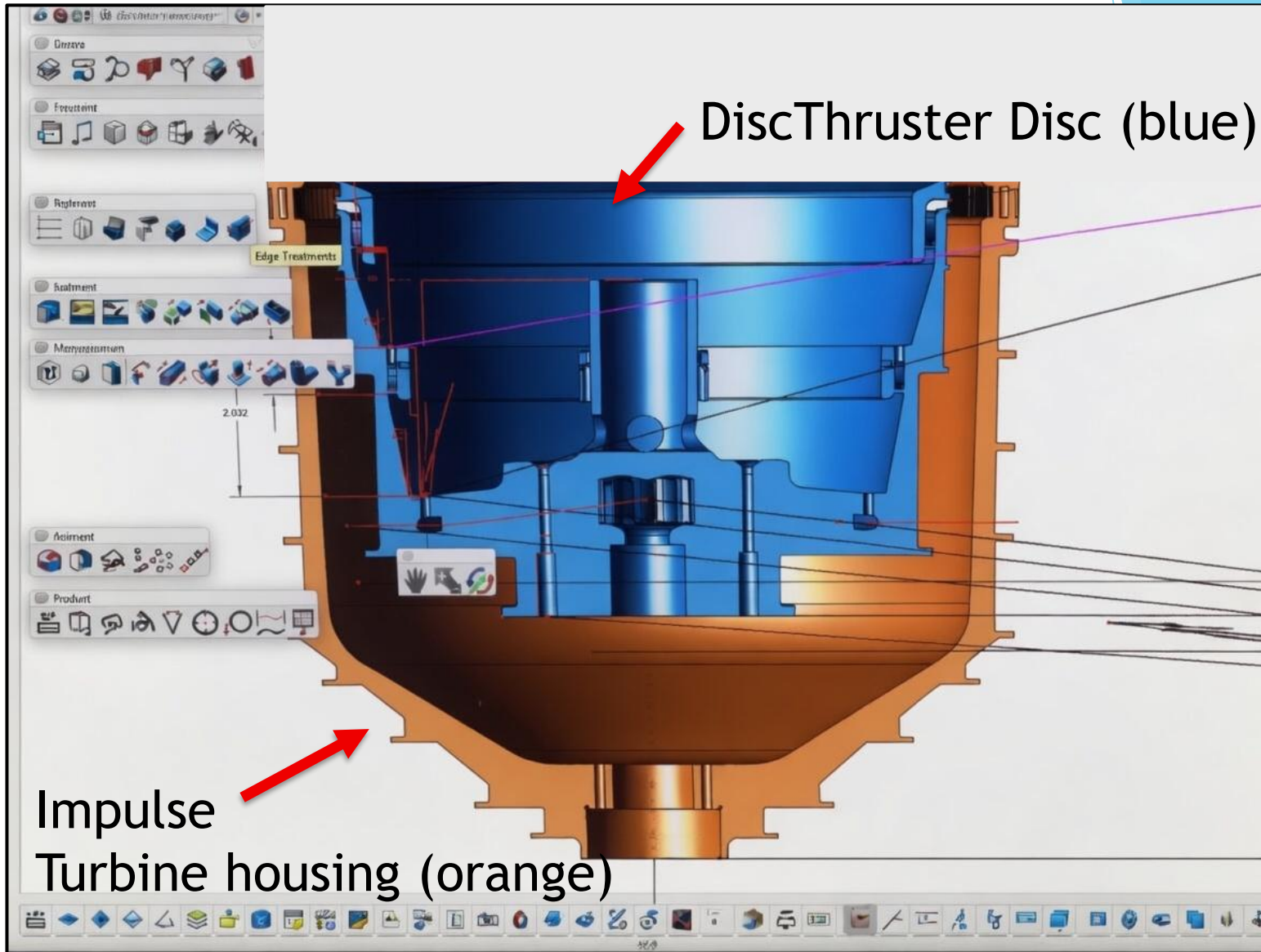

# DiscThruster - 5X5 Risk Chart

- All risks have mitigation plan to green (low risk)

		Consequence $\Rightarrow$ Worse				
Likelihood to Occur $\Uparrow$ Greater		(5) Can't control liquid flow velocity through turbomachinery (6) Lack of turboshaft engine choice.				
		(6) Guide new engine manufacturer designs. (5) Run experiments.	(4) Nozzle outlets cannot sense ambient outside pressure $P_\infty$ .		(1) Woods eqn. & slip ratio underpredicts velocity. (2) Poor gas capture.	
			(4) Run CFD. Adj. design as required.	(3) Unknown liquid metal flow behavior.		
		KEY Starting Risk $\Downarrow$ Mitigated Risk		(3) Run physical experiments to understand.		
		Green = Low risk Yellow = Medium risk Orange = High risk Red = Very high risk			(2) Run CFD. Make design changes. (1) Run CFD. Predict sonic velocity. Adj. performance.	

# DiscThruster - 5X5 Risk Chart

## Risk

## Risk Plus Risk Mitigation

1. Risk - Woods HEM equation underpredicts sonic velocities  
Mitigation - Run CFD analysis, adjust performance
2. Risk - Poor two-phase fluid gas capture  
Mitigation - Run CFD and simple experiments
3. Risk - Unknown liquid metal behavior  
Mitigation - Model fluid run experiments
4. Risk - Fluid leaving nozzles cannot sense outside ambient pressure environment  
Mitigation - Run CFD and simple experiments
5. Risk - Cannot control fluid velocity in turbo machinery  
Mitigation - Run CFD analysis and simple experiments
6. Risk - Air breathing version lacks mass production scalable source of existing commercial turboshaft engines  
Mitigation- Work with suppliers on production rate

# DiscThruster 4.0 - Rotating Sweeper Blades

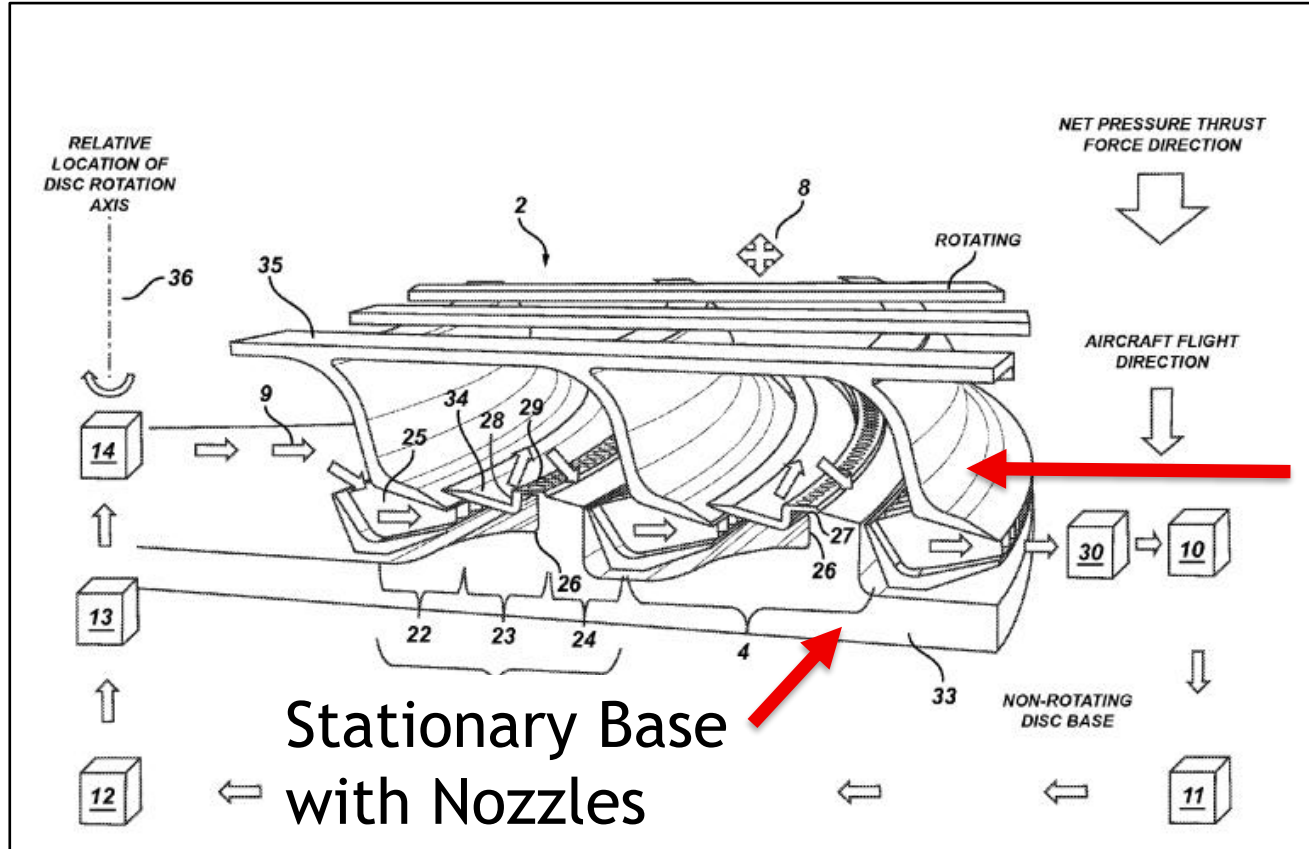

Rotating Sweeper Blades

- ❑ Stationary disc contains nozzles while rotating sweeper blades collect fluid exiting from nozzles
- ❑ Capture/Recycle design

# DiscThruster 5.0 - Reciprocating/Pulsing

- ❑ Nozzles Reciprocate/Pulse back and forth along nozzle centerline
  - Fluid forced through nozzles sonically chokes
  - Theoretically, if moving nozzle velocity equals fluid choking velocity, the fluid has zero velocity and zero kinetic energy losses
  - Simplifies rotating sweeper blade fluid collection
  - Ideal for high density two-phase fluids
- ❑ Capture/Recycle Design
- ❑ Concept only. Part of upcoming Patent

# SetllarJet - The Art of the Possible

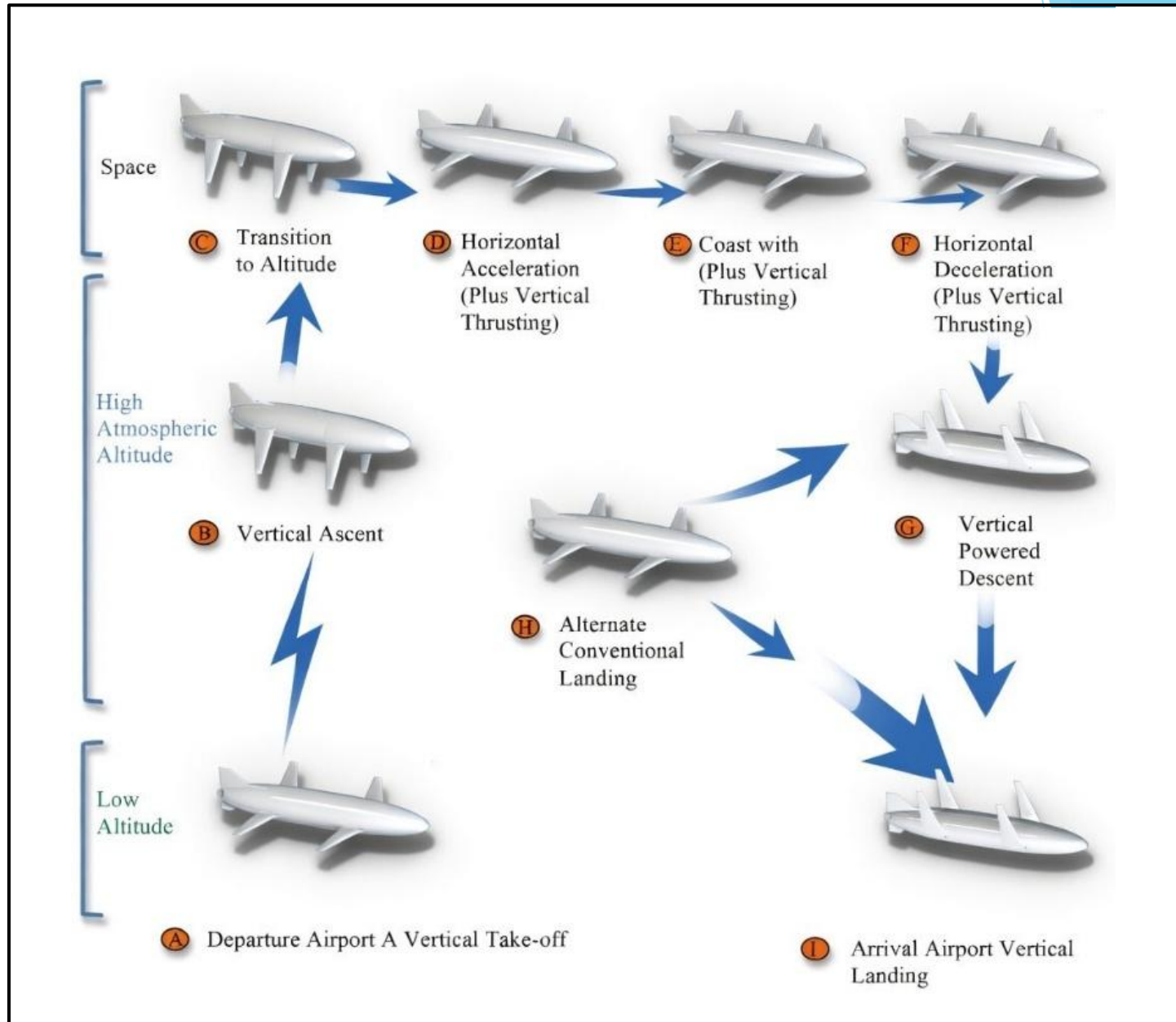

# DiscThruster 3.0 - Impulse Turbine

Impulse  
Turbine

Turbine  
“U” Shaped  
Blades

Drive Chain  
Sprocket

Carbon Fiber  
Hoop Overwrap

